

Welding Proximity Sensor E2EW Series

DC 3-wire

Stable detection in lines containing both aluminum and iron

- Equivalent sensing distances for both iron and aluminum ¹
- Enables common design for lines with both iron and aluminum
- The exceptional sensing range, reduces unexpected downtime
- Equipped with a function, which effectively cancels pulse noise of current magnetic field ¹.
- Omron's unique fluororesin coating technologies enable long-lasting spatter resistance, which lasts 60 times longer than previous models ².
- Durable full metal body to reduce downtime related to sensor damage.
- IO-Link is available for premium models.
- Sensing distances are laser printed on the sensor head for easy recognition ³.
- UL certification (UL60947-5-2) and
CSA certification (CSA C22.2 UL60947-5-2-14)

1. PREMIUM Models only.
2. Comparison with E2EF-Q products. Based on June 2019 OMRON investigation.
3. Models without spatter-resistant coating only.



For the most recent information on models that have been certified for safety standards, refer to your Omron website.



Be sure to read *Safety Precautions* on page 23.

E2EW Series Model Number Legend

DC 3-wire

E2EW - (1) X (2) (3) (4) (5) (6) - (7) (8)

No.	Type	Code	Meaning
(1)	Case	Blank	Without spatter-resistant coating
		Q	With spatter-resistant coating
(2)	Sensing distance	Number	Sensing distance (Unit: mm)
(3)	Output configuration	B	PNP open collector
		C	NPN open collector
(4)	Operation mode	1	Normally open (NO)
		2	Normally closed (NC)
		3	Normally open, Normally closed (NO+NC)
(5)	IO-Link baud rate	Blank	Non IO-Link compliant
		D	COM2 (38.4kbps)
		T	COM3 (230.4kbps)
(6)	Size	12	M12
		18	M18
		30	M30
(7)	Connection method	Blank	Pre-wired Models
		M1TJ	M12 Pre-wired Smartclick Connector Models
(8)	Cable length	Number M	Cable length

Note: The purpose of this model number legend is to provide understanding of the meaning of specifications from the model number. Models are not available for all combinations of code numbers.

E2EW Series

Ordering Information

PREMIUM Model

E2EW Series (Quadruple distance model)

DC 3-wire [Refer to *Dimensions* on page 26.]

Shielded ¹

Size (Sensing distance)	Connection method	Operation mode	Model	
			PNP	NPN
M18 (12 mm)	Pre-wired (2 m) ²	NO	E2EW-X12B1T18 2M	E2EW-X12C118 2M
		NC	E2EW-X12B218 2M	E2EW-X12C218 2M
		NO+NC	E2EW-X12B3T18 2M	---
	M12 Pre-wired Smartclick Connector (0.3 m)	NO	E2EW-X12B1T18-M1TJ 0.3M	E2EW-X12C118-M1TJ 0.3M
		NC	E2EW-X12B218-M1TJ 0.3M	E2EW-X12C218-M1TJ 0.3M
		NO+NC	E2EW-X12B3T18-M1TJ 0.3M	---
M30 (22 mm)	Pre-wired (2 m) ²	NO	E2EW-X22B1T30 2M	E2EW-X22C130 2M
		NC	E2EW-X22B230 2M	E2EW-X22C230 2M
		NO+NC	E2EW-X22B3T30 2M	---
	M12 Pre-wired Smartclick Connector (0.3 m)	NO	E2EW-X22B1T30-M1TJ 0.3M	E2EW-X22C130-M1TJ 0.3M
		NC	E2EW-X22B230-M1TJ 0.3M	E2EW-X22C230-M1TJ 0.3M
		NO+NC	E2EW-X22B3T30-M1TJ 0.3M	---

1. When embedding the Proximity Sensor in metal, refer to *Influence of Surrounding Metal* on page 24.

2. Models with 5-m cable length are also available with "5M" suffix. (Example: E2EW-X12B1T18 5M)

Note: 1. Models in are equipped with IO-Link (COM3). For IO-Link (COM2), select a model number with the format of "E2EW-X□□□D□" (Example: E2EW-X12B1D18 2M).

Operation mode NO can be changed to NC via IO-Link communications.

2. IO-Link is not supported for NC-type PNP outputs or all types of NPN outputs.

PREMIUM Model

E2EW Series (Triple distance model)

DC 3-wire [Refer to *Dimensions* on page 26.]Shielded ¹

Size (Sensing distance)	Connection method	Operation mode	Model	
			PNP	NPN
M18 (10 mm)	Pre-wired (2 m) ²	NO	E2EW-X10B1T18 2M	E2EW-X10C118 2M
		NC	E2EW-X10B218 2M	E2EW-X10C218 2M
		NO+NC	E2EW-X10B3T18 2M	---
	M12 Pre-wired Smartclick Connector (0.3 m)	NO	E2EW-X10B1T18-M1TJ 0.3M	E2EW-X10C118-M1TJ 0.3M
		NC	E2EW-X10B218-M1TJ 0.3M	E2EW-X10C218-M1TJ 0.3M
		NO+NC	E2EW-X10B3T18-M1TJ 0.3M	---
M30 (20 mm)	Pre-wired (2 m) ²	NO	E2EW-X20B1T30 2M	E2EW-X20C130 2M
		NC	E2EW-X20B230 2M	E2EW-X20C230 2M
		NO+NC	E2EW-X20B3T30 2M	---
	M12 Pre-wired Smartclick Connector (0.3 m)	NO	E2EW-X20B1T30-M1TJ 0.3M	E2EW-X20C130-M1TJ 0.3M
		NC	E2EW-X20B230-M1TJ 0.3M	E2EW-X20C230-M1TJ 0.3M
		NO+NC	E2EW-X20B3T30-M1TJ 0.3M	---

1. When embedding the Proximity Sensor in metal, refer to *Influence of Surrounding Metal* on page 24.

2. Models with 5-m cable length are also available with "5M" suffix. (Example: E2EW-X10B1T18 5M)

Note: 1. Models in are equipped with IO-Link (COM3). For IO-Link (COM2), select a model number with the format of "E2EW-X□□□D□" (Example: E2EW-X10B1D18 2M).

Operation mode NO can be changed to NC via IO-Link communications.

2. IO-Link is not supported for NC-type PNP outputs or all types of NPN outputs.

E2EW Series

PREMIUM Model

E2EW-Q Series (Spatter-resistant Quadruple distance model)

DC 3-wire [Refer to *Dimensions* on page 26.]

Shielded ¹

Size (Sensing distance)	Connection method	Operation mode	Model	
			PNP	NPN
M18 (12 mm)	Pre-wired (2 m) ²	NO	E2EW-QX12B1T18 2M	E2EW-QX12C118 2M
		NC	E2EW-QX12B218 2M	E2EW-QX12C218 2M
		NO+NC	E2EW-QX12B3T18 2M	---
	M12 Pre-wired Smartclick Connector (0.3 m)	NO	E2EW-QX12B1T18-M1TJ 0.3M	E2EW-QX12C118-M1TJ 0.3M
		NC	E2EW-QX12B218-M1TJ 0.3M	E2EW-QX12C218-M1TJ 0.3M
		NO+NC	E2EW-QX12B3T18-M1TJ 0.3M	---
M30 (22 mm)	Pre-wired (2 m) ²	NO	E2EW-QX22B1T30 2M	E2EW-QX22C130 2M
		NC	E2EW-QX22B230 2M	E2EW-QX22C230 2M
		NO+NC	E2EW-QX22B3T30 2M	---
	M12 Pre-wired Smartclick Connector (0.3 m)	NO	E2EW-QX22B1T30-M1TJ 0.3M	E2EW-QX22C130-M1TJ 0.3M
		NC	E2EW-QX22B230-M1TJ 0.3M	E2EW-QX22C230-M1TJ 0.3M
		NO+NC	E2EW-QX22B3T30-M1TJ 0.3M	---

1. When embedding the Proximity Sensor in metal, refer to *Influence of Surrounding Metal* on page 24.

2. Models with 5-m cable length are also available with "5M" suffix. (Example: E2EW-QX12B1T18 5M)

Note: 1. Models in are equipped with IO-Link (COM3). For IO-Link (COM2), select a model number with the format of "E2EW-QX□□□D□"
(Example: E2EW-QX12B1D18 2M).

Operation mode NO can be changed to NC via IO-Link communications.

2. IO-Link is not supported for NC-type PNP outputs or all types of NPN outputs.

PREMIUM Model

E2EW-Q Series (Spatter-resistant Triple distance model)

DC 3-wire [Refer to *Dimensions* on page 26.]Shielded ¹

Size (Sensing distance)	Connection method	Operation mode	Model	
			PNP	NPN
M18 (10 mm)	Pre-wired (2 m) ²	NO	E2EW-QX10B1T18 2M	E2EW-QX10C118 2M
		NC	E2EW-QX10B218 2M	E2EW-QX10C218 2M
		NO+NC	E2EW-QX10B3T18 2M	---
	M12 Pre-wired Smartclick Connector (0.3 m)	NO	E2EW-QX10B1T18-M1TJ 0.3M	E2EW-QX10C118-M1TJ 0.3M
		NC	E2EW-QX10B218-M1TJ 0.3M	E2EW-QX10C218-M1TJ 0.3M
		NO+NC	E2EW-QX10B3T18-M1TJ 0.3M	---
M30 (20 mm)	Pre-wired (2 m) ²	NO	E2EW-QX20B1T30 2M	E2EW-QX20C130 2M
		NC	E2EW-QX20B230 2M	E2EW-QX20C230 2M
		NO+NC	E2EW-QX20B3T30 2M	---
	M12 Pre-wired Smartclick Connector (0.3 m)	NO	E2EW-QX20B1T30-M1TJ 0.3M	E2EW-QX20C130-M1TJ 0.3M
		NC	E2EW-QX20B230-M1TJ 0.3M	E2EW-QX20C230-M1TJ 0.3M
		NO+NC	E2EW-QX20B3T30-M1TJ 0.3M	---

1. When embedding the Proximity Sensor in metal, refer to *Influence of Surrounding Metal* on page 24.

2. Models with 5-m cable length are also available with "5M" suffix. (Example: E2EW-QX10B1T18 5M)

Note: 1. Models in are equipped with IO-Link (COM3). For IO-Link (COM2), select a model number with the format of "E2EW-QX□□□D□"
(Example: E2EW-QX10B1D18 2M).

Operation mode NO can be changed to NC via IO-Link communications.

2. IO-Link is not supported for NC-type PNP outputs or all types of NPN outputs.

E2EW Series

BASIC Model

E2EW Series (Single distance model)

DC 3-wire [Refer to *Dimensions* on page 26.]

Shielded

Size (Sensing distance)	Connection method	Operation mode	Model	
			PNP	NPN
M12 (2 mm)	Pre-wired (2 m) ¹	NO	E2EW-X2B112 2M	E2EW-X2C112 2M
		NC	E2EW-X2B212 2M	E2EW-X2C212 2M
		NO+NC	E2EW-X2B312 2M	E2EW-X2C312 2M
	M12 Pre-wired Smartclick Connector (0.3 m)	NO	E2EW-X2B112-M1TJ 0.3M	E2EW-X2C112-M1TJ 0.3M
		NC	E2EW-X2B212-M1TJ 0.3M	E2EW-X2C212-M1TJ 0.3M
		NO+NC	E2EW-X2B312-M1TJ 0.3M	E2EW-X2C312-M1TJ 0.3M
M18 (5 mm)	Pre-wired (2 m) ¹	NO	E2EW-X5B118 2M	E2EW-X5C118 2M
		NC	E2EW-X5B218 2M	E2EW-X5C218 2M
		NO+NC	E2EW-X5B318 2M	E2EW-X5C318 2M
	M12 Pre-wired Smartclick Connector (0.3 m)	NO	E2EW-X5B118-M1TJ 0.3M	E2EW-X5C118-M1TJ 0.3M
		NC	E2EW-X5B218-M1TJ 0.3M	E2EW-X5C218-M1TJ 0.3M
		NO+NC	E2EW-X5B318-M1TJ 0.3M	E2EW-X5C318-M1TJ 0.3M
M30 (10 mm)	Pre-wired (2 m) ¹	NO	E2EW-X10B130 2M	E2EW-X10C130 2M
		NC	E2EW-X10B230 2M	E2EW-X10C230 2M
		NO+NC	E2EW-X10B330 2M	E2EW-X10C330 2M
	M12 Pre-wired Smartclick Connector (0.3 m)	NO	E2EW-X10B130-M1TJ 0.3M	E2EW-X10C130-M1TJ 0.3M
		NC	E2EW-X10B230-M1TJ 0.3M	E2EW-X10C230-M1TJ 0.3M
		NO+NC	E2EW-X10B330-M1TJ 0.3M	E2EW-X10C330-M1TJ 0.3M

1. Models with 5-m cable length are also available with "5M" suffix. (Example: E2EW-X2B112 5M)

Note: IO-Link is not supported for all types of BASIC Model.

BASIC Model

E2EW-Q Series (Spatter-resistant Single distance model)

DC 3-wire [Refer to *Dimensions* on page 26.]

Shielded

Size (Sensing distance)	Connection method	Operation mode	Model	
			PNP	NPN
M12 (2 mm)	Pre-wired (2 m) ¹	NO	E2EW-QX2B112 2M	E2EW-QX2C112 2M
		NC	E2EW-QX2B212 2M	E2EW-QX2C212 2M
		NO+NC	E2EW-QX2B312 2M	E2EW-QX2C312 2M
	M12 Pre-wired Smartclick Connector (0.3 m)	NO	E2EW-QX2B112-M1TJ 0.3M	E2EW-QX2C112-M1TJ 0.3M
		NC	E2EW-QX2B212-M1TJ 0.3M	E2EW-QX2C212-M1TJ 0.3M
		NO+NC	E2EW-QX2B312-M1TJ 0.3M	E2EW-QX2C312-M1TJ 0.3M
M18 (5 mm)	Pre-wired (2 m) ¹	NO	E2EW-QX5B118 2M	E2EW-QX5C118 2M
		NC	E2EW-QX5B218 2M	E2EW-QX5C218 2M
		NO+NC	E2EW-QX5B318 2M	E2EW-QX5C318 2M
	M12 Pre-wired Smartclick Connector (0.3 m)	NO	E2EW-QX5B118-M1TJ 0.3M	E2EW-QX5C118-M1TJ 0.3M
		NC	E2EW-QX5B218-M1TJ 0.3M	E2EW-QX5C218-M1TJ 0.3M
		NO+NC	E2EW-QX5B318-M1TJ 0.3M	E2EW-QX5C318-M1TJ 0.3M
M30 (10 mm)	Pre-wired (2 m) ¹	NO	E2EW-QX10B130 2M	E2EW-QX10C130 2M
		NC	E2EW-QX10B230 2M	E2EW-QX10C230 2M
		NO+NC	E2EW-QX10B330 2M	E2EW-QX10C330 2M
	M12 Pre-wired Smartclick Connector (0.3 m)	NO	E2EW-QX10B130-M1TJ 0.3M	E2EW-QX10C130-M1TJ 0.3M
		NC	E2EW-QX10B230-M1TJ 0.3M	E2EW-QX10C230-M1TJ 0.3M
		NO+NC	E2EW-QX10B330-M1TJ 0.3M	E2EW-QX10C330-M1TJ 0.3M



1. Models with 5-m cable length are also available with "5M" suffix. (Example: E2EW-QX2B112 5M)

Note: IO-Link is not supported for all types of BASIC Model.

Accessories (Sold Separately)

Sensor I/O Connectors

(Models for Pre-wired Connectors) A Sensor I/O Connector is not provided with the Sensor. Order separately as required.
 Round Water-resistant Connectors XS5 series

Appearance	Cable Specification	Type	Cable diameter (mm)	Cable Connection Direction	Cable length (m)	Sensor I/O Connector model number	Applicable Proximity Sensor model number
M12 Smartclick Connector Straight type  Right-angle type 	PVC robot cable	Sockets on One Cable End	6 dia.	Straight	1	XS5F-D421-C80-F	E2EW-X□□□-M1TJ E2EW-QX□□□-M1TJ
					2	XS5F-D421-D80-F	
					3	XS5F-D421-E80-F	
					5	XS5F-D421-G80-F	
					10	XS5F-D421-J80-F	
				Right-angle	1	XS5F-D422-C80-F	
					2	XS5F-D422-D80-F	
					3	XS5F-D422-E80-F	
					5	XS5F-D422-G80-F	
					10	XS5F-D422-J80-F	
		Socket and Plug on Cable Ends	6 dia.	Straight (Socket)/ Straight (Plug)	1	XS5W-D421-C81-F	
					2	XS5W-D421-D81-F	
					3	XS5W-D421-E81-F	
					5	XS5W-D421-G81-F	
					10	XS5W-D421-J81-F	
				Right-angle (Socket)/ Right-angle (Plug)	2	XS5W-D422-D81-F	
					5	XS5W-D422-G81-F	
				Straight (Socket)/ Right-angle (Plug)	2	XS5W-D423-D81-F	
5	XS5W-D423-G81-F						
Right-angle (Socket)/ Straight (Plug)	2	XS5W-D424-D81-F					
	5	XS5W-D424-G81-F					

Note: For details of the connector, refer to XS5 Series datasheet.

Ratings and Specifications

PREMIUM Model

E2EW Series (Quadruple/Triple distance model)

E2EW-Q Series (Spatter-resistant Quadruple/Triple distance model)

DC 3-wire

Shielded

Item	Type Size Model	Quadruple distance model		Triple distance model	
		M18	M30	M18	M30
		E2EW(-Q)X12□18	E2EW(-Q)X22□30	E2EW(-Q)X10□18	E2EW(-Q)X20□30
Sensing distance		12 mm ±10%	22 mm ±10%	10 mm ±10%	20 mm ±10%
Setting distance		0 to 8.4 mm	0 to 15.4 mm	0 to 7.0 mm	0 to 14 mm
Differential travel		15% max. of sensing distance			
Detectable object		Ferrous metals and non-ferrous metals (The sensing distance depends on the material of the sensing object. Refer to <i>Engineering Data</i> on page 11.)			
Standard sensing object		Iron, 36 × 36 × 1 mm	Iron, 66 × 66 × 1 mm	Iron, 30 × 30 × 1 mm	Iron, 60 × 60 × 1 mm
Response frequency ^{1 2}		2 Hz			
Power supply voltage		10 to 30 VDC (including 10% ripple (p-p)), Class 2			
Current consumption		720 mW max. (Current consumption: 30 mA max. at power supply voltage of 24 V)			
Output configuration		B□ Models: PNP open collector, C□ Models: NPN open collector			
Operation mode		1-output models (B1, C1): NO (Normally open), 1-output models (B2, C2): NC (Normally closed), 2-output models (B3): NO+NC (Normally open, Normally closed)			
Control output	Load current	1-output models (B1,B2,C1,C2): 10 to 30 VDC, Class 2, 200 mA max. 2-output models (B3): 10 to 30 VDC, Class 2, 100 mA max.			
	Residual voltage	1-output models (B1,B2,C1,C2): 2 V max. (Load current: 200 mA, Cable length: 2 m) 2-output models (B3): 2 V max. (Load current: 100 mA, Cable length: 2 m)			
Indicator		In the Standard I/O mode (SIO mode): Operation indicator (orange, lit) and communication indicator (green, not lit) In the IO-Link communication mode (COM mode): Operation indicator (orange, lit) and communication indicator (green, blinking at 1 s intervals)			
Protection circuits		Power supply reverse polarity protection, Surge suppressor, Output short-circuit protection, Output reverse polarity protection			
Ambient temperature range		Operating: 0 to 85 °C, Storage: -15 to 85 °C (with no icing or condensation) ³			
Ambient humidity range		Operating/Storage: 35% to 95% (with no condensation)			
Temperature influence		±20% max. of sensing distance at 23 °C in the temperature range of 0 to 85 °C			
Voltage influence		±1.5% max. of sensing distance at rated voltage in the rated voltage ±15% range			
Insulation resistance		50 MΩ min. (at 500 VDC) between current-carrying parts and case			
Dielectric strength		1,000 VAC, 50/60 Hz for 1 minute between current-carrying parts and case			
Vibration resistance (destruction)		10 to 55 Hz, 1.5-mm double amplitude for 2 hours each in X, Y, and Z directions			
Shock resistance (destruction)		1,000 m/s ² 10 times each in X, Y, and Z directions			
Degree of protection		IEC 60529: IP67			
Connection method		Pre-wired Models (Standard cable length: 2 m), Pre-wired Connector Models (Standard cable length: 0.3 m)			
Weight (packed state)	Pre-wired	Approx. 165 g	Approx. 225 g	Approx. 165 g	Approx. 225 g
	M12 Pre-wired Smartclick Connector	Approx. 100 g	Approx. 160 g	Approx. 100 g	Approx. 160 g
Materials	Case	E2EW-X□: Stainless steel (SUS303), E2EW-QX□: Fluororesin coating (Base material: (SUS303))			
	Sensing surface	E2EW-X□: Stainless steel (SUS303), E2EW-QX□: Fluororesin coating (Base material: (SUS303))			
	Sensing surface (Thickness)	0.4 mm	0.5 mm	0.4 mm	0.5 mm
	Clamping nuts	E2EW-X□: Stainless steel (SUS303), E2EW-QX□: Fluororesin coating (Base material: (SUS303))			
	Toothed washers	Zinc-plated iron			
Cable	Vinyl chloride (PVC)				
Main IO-Link functions ⁴		Operation mode switching between NO and NC, self diagnosis, excessive target proximity, alarm selection, control output timer function (ON delay, OFF delay, one shot options), monitor output, operating hours read-out, readout of the sensor internal temperature, and initial reset			
IO-Link Communication specifications ³	IO-Link specification	Ver.1.1			
	Baud rate	E2EW(-Q) X□B□□□: COM3 (230.4 kbps), E2EW(-Q) X□B□□□: COM2 (38.4 kbps)			
	Data length	PD size: 2 bytes, OD size: 1 byte (M-sequence type: TYPE_2_2)			
	Minimum cycle time	COM2: 2.3 ms, COM3: 1.0 ms			
Accessories		Instruction manual, Clamping nuts, Toothed washer			

1. The response frequency is an average value.

2. Factory setting: (timer function: ONOFF delay, timer time: 200 ms).

3. UL Temperature rating is between 0°C to 60°C.

4. IO-Link is not supported for NC-type PNP outputs or all types of NPN outputs.

E2EW Series

BASIC Model

E2EW Series (Single distance model)

E2EW-Q Series (Spatter-resistant Single distance model)

DC 3-wire

Shielded

Item	Type Size Model	Single distance model		
		M12	M18	M30
		E2EW-(Q)X2□12	E2EW-(Q)X5□18	E2EW-(Q)X10□30
Sensing distance		2 mm ±10%	5 mm ±10%	10 mm ±10%
Setting distance		0 to 1.4 mm	0 to 3.5 mm	0 to 7 mm
Differential travel		10% max. of sensing distance		
Detectable object		Ferrous metals and non-ferrous metals (The sensing distance depends on the material of the sensing object. Refer to <i>Engineering Data</i> on page 11.)		
Standard sensing object		Iron, 12 × 12 × 1 mm	Iron, 18 × 18 × 1 mm	Iron, 30 × 30 × 1 mm
Response frequency ¹		100 Hz	80 Hz	40 Hz
Power supply voltage		10 to 30 VDC (including 10% ripple (p-p)), Class 2		
Current consumption		1-output models (B1, B2, C1, C2): 16 mA max. 2-output models (B3, C3): 20 mA max.		
Output configuration		B□ Models: PNP open collector, C□ Models: NPN open collector		
Operation mode		1-output models (B1, C1): NO (Normally open), 1-output models (B2, C2): NC (Normally closed), 2-output models (B3, C3): NO+NC (Normally open, Normally closed)		
Control output	Load current	1-output models (B1, B2, C1, C2): 10 to 30 VDC, Class 2, 200 mA max. 2-output models (B3, C3): 10 to 30 VDC, Class 2, 100 mA max.		
	Residual voltage	1-output models (B1, B2, C1, C2): 2 V max. (Load current: 200 mA, Cable length: 2 m) 2-output models (B3, C3): 2 V max. (Load current: 100 mA, Cable length: 2 m)		
Indicator		Operation indicator (orange, lit) and communication indicator (green, not lit)		
Protection circuits		Power supply reverse polarity protection, Surge suppressor, Output short-circuit protection, Output reverse polarity protection		
Ambient temperature range		Operating: 0 to 85 °C, Storage: -15 to 85 °C (with no icing or condensation) ²		
Ambient humidity range		Operating/Storage: 35% to 95% (with no condensation)		
Temperature influence		±20% max. of sensing distance at 23 °C in the temperature range of 0 to 85 °C		
Voltage influence		±1.5% max. of sensing distance at rated voltage in the rated voltage ±15% range		
Insulation resistance		50 MΩ min. (at 500 VDC) between current-carrying parts and case		
Dielectric strength		1,000 VAC, 50/60 Hz for 1 minute between current-carrying parts and case		
Vibration resistance (destruction)		10 to 55 Hz, 1.5-mm double amplitude for 2 hours each in X, Y, and Z directions		
Shock resistance (destruction)		1,000 m/s ² 10 times each in X, Y, and Z directions		
Degree of protection		IEC 60529: IP67		
Connection method		Pre-wired Models (Standard cable length: 2 m), Pre-wired Connector Models (Standard cable length: 0.3 m)		
Weight (packed state)	Pre-wired	Approx. 140 g	Approx. 160 g	Approx. 225 g
	M12 Pre-wired Smartclick Connector	Approx. 70 g	Approx. 95 g	Approx. 160 g
Materials	Case	E2EW-X□: Stainless steel (SUS303), E2EW-QX□: Fluororesin coating (Base material: (SUS303))		
	Sensing surface	E2EW-X□: Stainless steel (SUS303), E2EW-QX□: Fluororesin coating (Base material: (SUS303))		
	Sensing surface (Thickness)	0.8 mm	0.8 mm	0.8 mm
	Clamping nuts	E2EW-X□: Stainless steel (SUS303), E2EW-QX□: Fluororesin coating (Base material: (SUS303))		
	Toothed washers	Zinc-plated iron		
Cable		Vinyl chloride (PVC)		
Accessories		Instruction manual, Clamping nuts, Toothed washer		

1. The response frequency is an average value. Measurement conditions are as follows: standard sensing object, a distance of twice the standard sensing object, and a set distance of half the sensing distance.

2. UL Temperature rating is between 0°C to 60°C.

Engineering Data (Reference Value)

Sensing Area

PREMIUM Model

**Quadruple distance model/
Spatter-resistant Quadruple distance model
Shielded**

Sensing object: iron

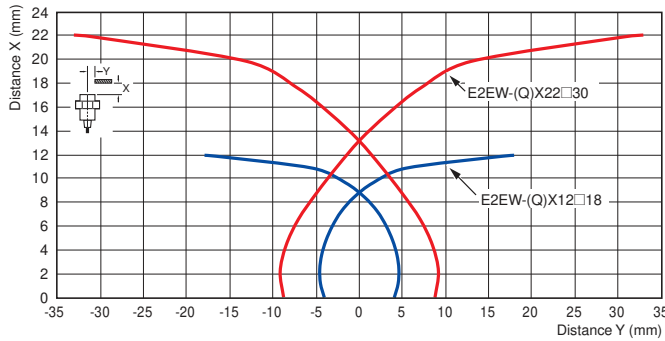

Sensing object: Aluminum

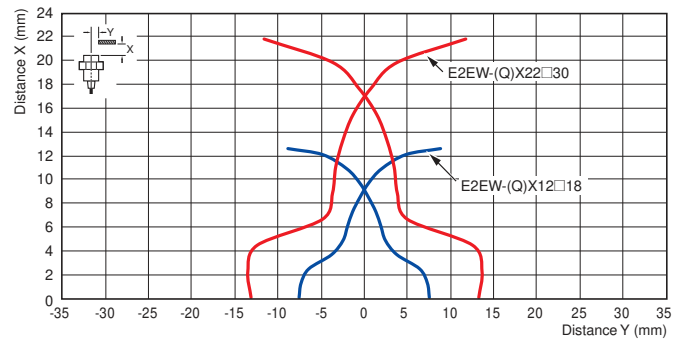

**Triple distance model/
Spatter-resistant Triple distance model
Shielded**

Sensing object: iron

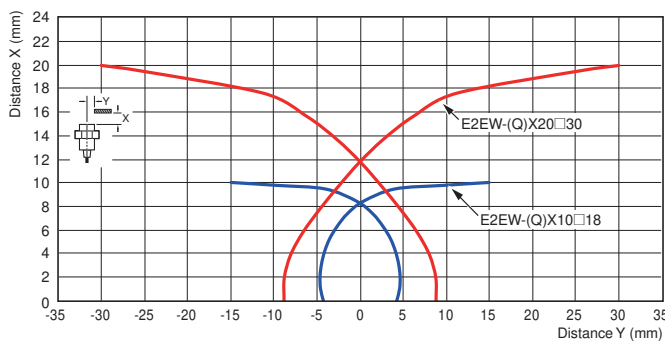

Sensing object: Aluminum

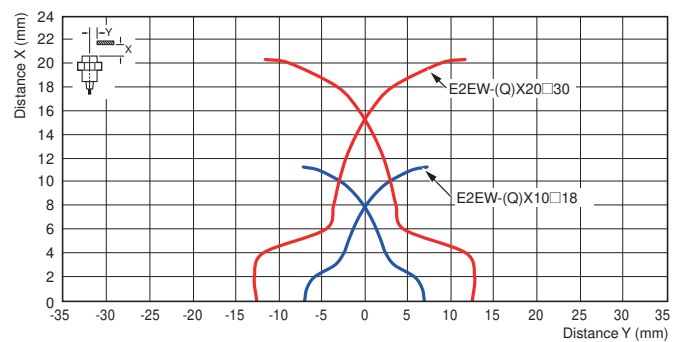

BASIC Model

**Single distance model/
Spatter-resistant Single distance model
Shielded**

Sensing object: iron

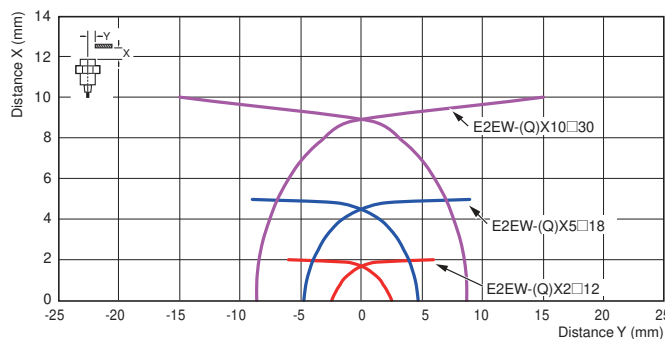

Influence of Sensing Object Size and Material

PREMIUM Model

**Quadruple distance model/
Spatter-resistant Quadruple distance model
Shielded**

Size: M18 E2EW-(Q)X12□18

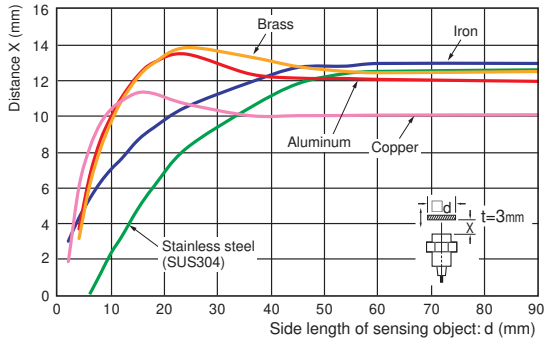

Size: M30 E2EW-(Q)X22□30

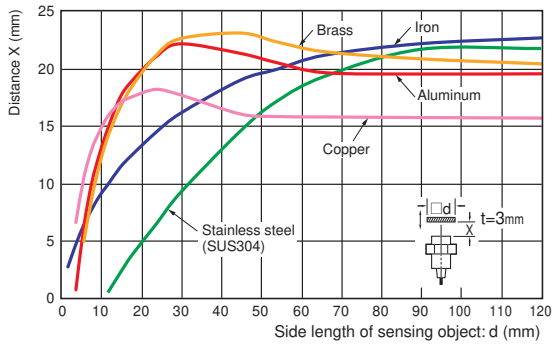

**Triple distance model/
Spatter-resistant Triple distance model
Shielded**

Size: M18 E2EW-(Q)X10□18

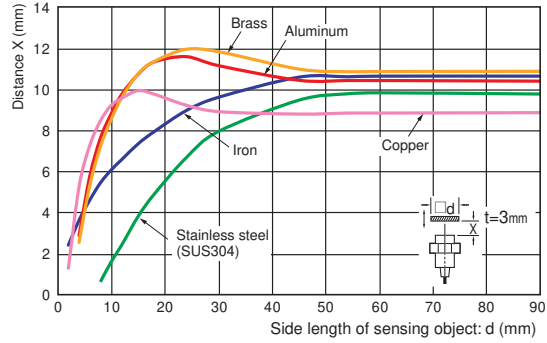

Size: M30 E2EW-(Q)X20□30

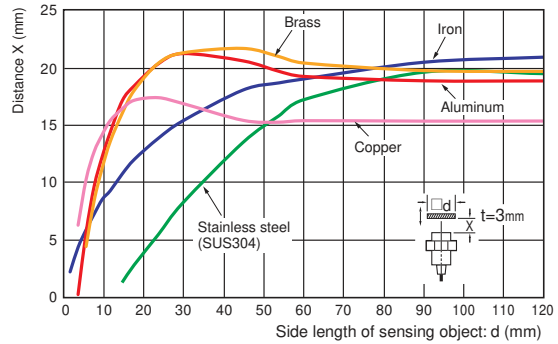

BASIC Model

Single distance model/
Spatter-resistant Single distance model
Shielded

Size: M12 E2EW-(Q)X2□12

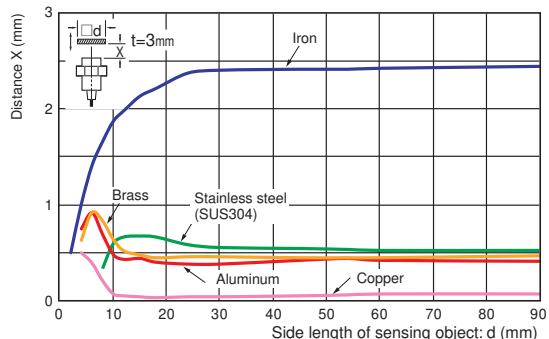

Size: M18 E2EW-(Q)X5□18

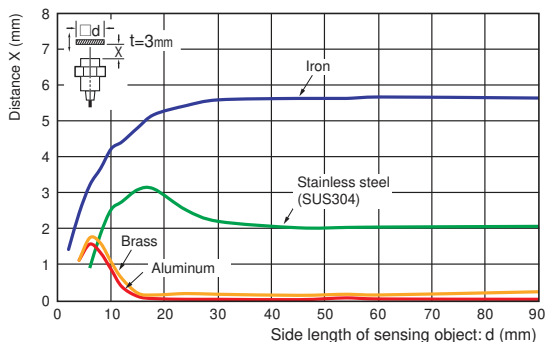

Size: M30 E2EW-(Q)X10□30

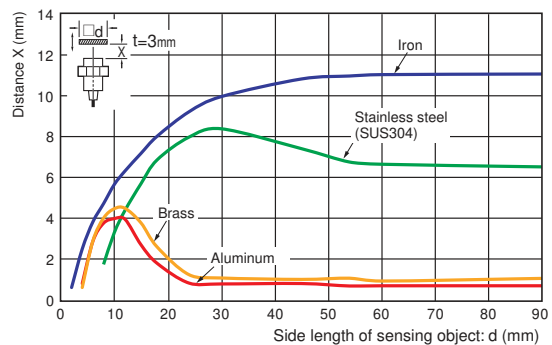

Influence of Sensing Object Thickness and Material

PREMIUM Model

**Quadruple distance model/
Spatter-resistant Quadruple distance model
Shielded**

Size: M18 E2EW-(Q)X12□18

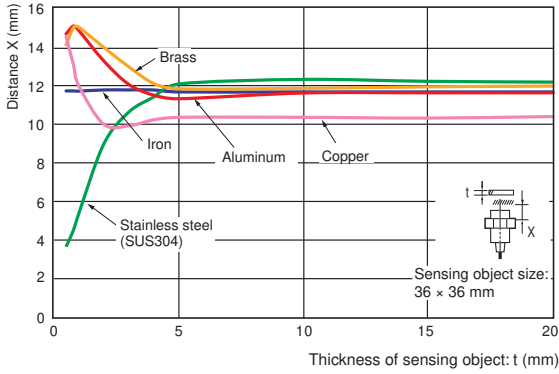

Size: M30 E2EW-(Q)X22□30

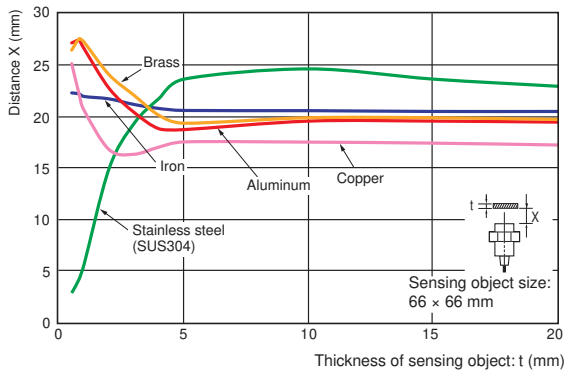

**Triple distance model/
Spatter-resistant Triple distance model
Shielded**

Size: M18 E2EW-(Q)X10□18

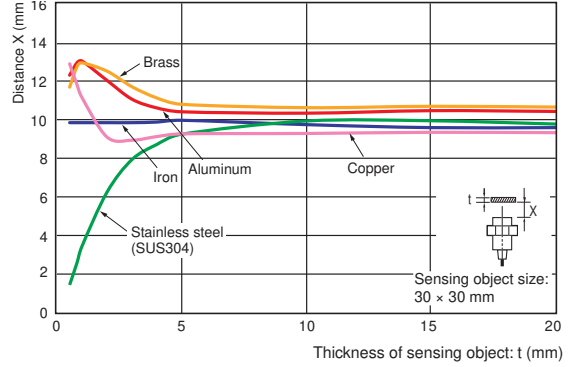

Size: M30 E2EW-(Q)X20□30

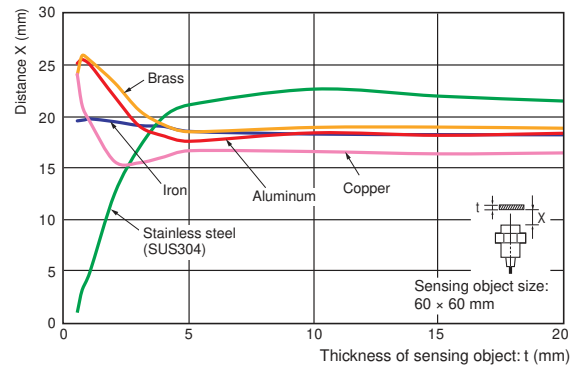

BASIC Model

Single distance model/
 Spatter-resistant Single distance model
 Shielded

Size: M12 E2EW-(Q)X2□12

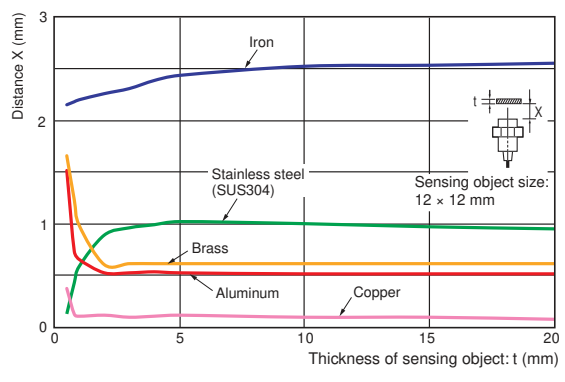

Size: M18 E2EW-(Q)X5□18

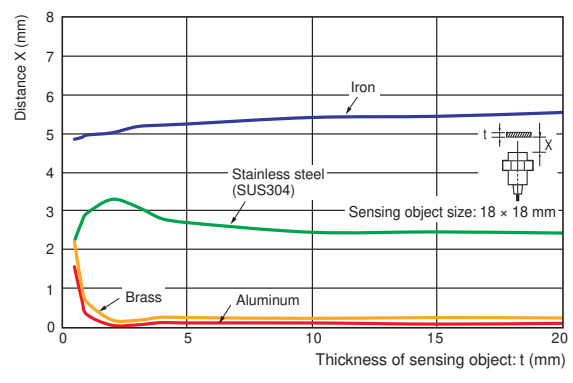

Size: M30 E2EW-(Q)X10□30

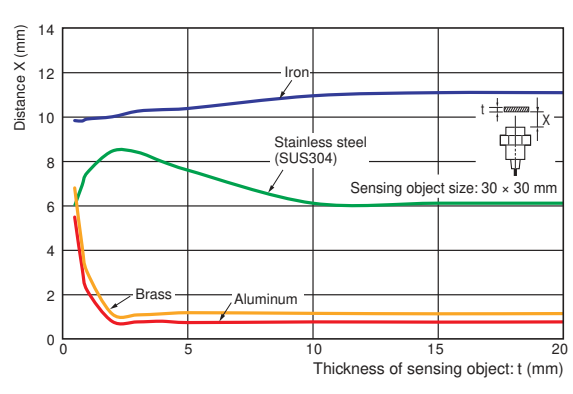

Monitor Output vs. Sensing Distance

PREMIUM Model

Quadruple distance model/
Spatter-resistant Quadruple distance model
Shielded

Size: M18 E2EW-(Q)X12□18

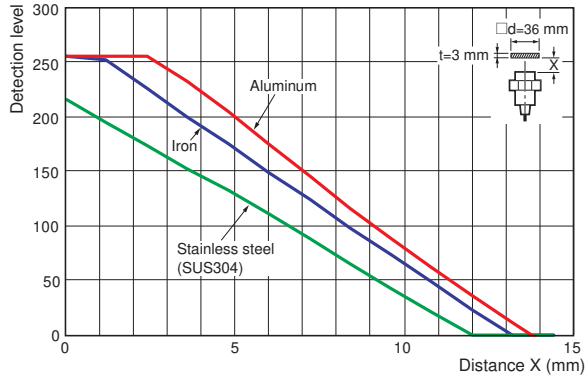

Size: M30 E2EW-(Q)X22□30

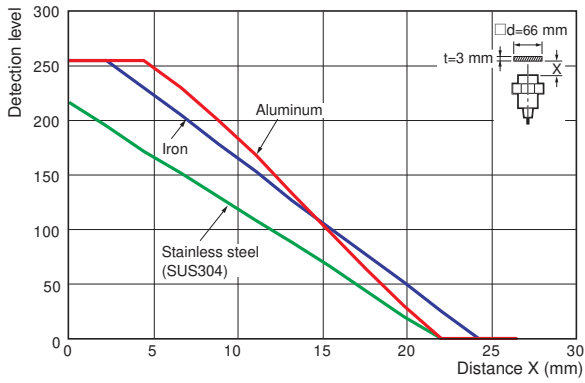

Triple distance model/
Spatter-resistant Triple distance model
Shielded

Size: M18 E2EW-(Q)X10□18

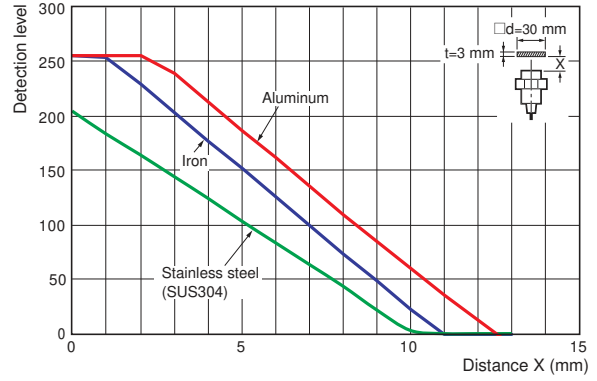

Size: M30 E2EW-(Q)X20□30

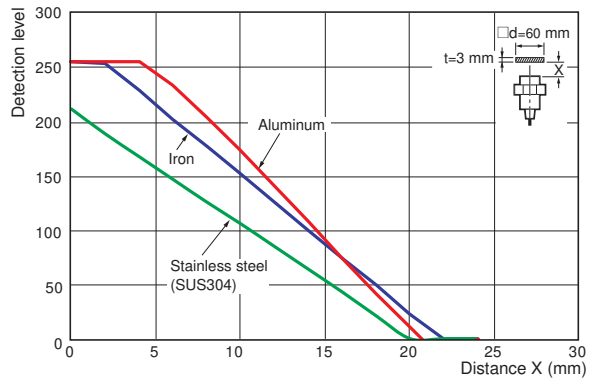

I/O Circuit Diagrams/Timing charts

DC 3-wire

PNP output

PREMIUM Model

Operation mode	Model	Output circuit	
		Standard I/O mode (SIO mode) When using as a general	IO-Link Communication mode (COM mode) When using the Sensor connected to IO-Link Master Unit
NO	E2EW-(Q)X□B1		
NC	E2EW-(Q)X□B2		---
NO+NC	E2EW-(Q)X□B3		

In the IO-Link mode, the cord between the IO-Link master and sensor must have a length of 20 m or less.

Connector Pin Arrangement

M12 Smartclick Connector



PNP output

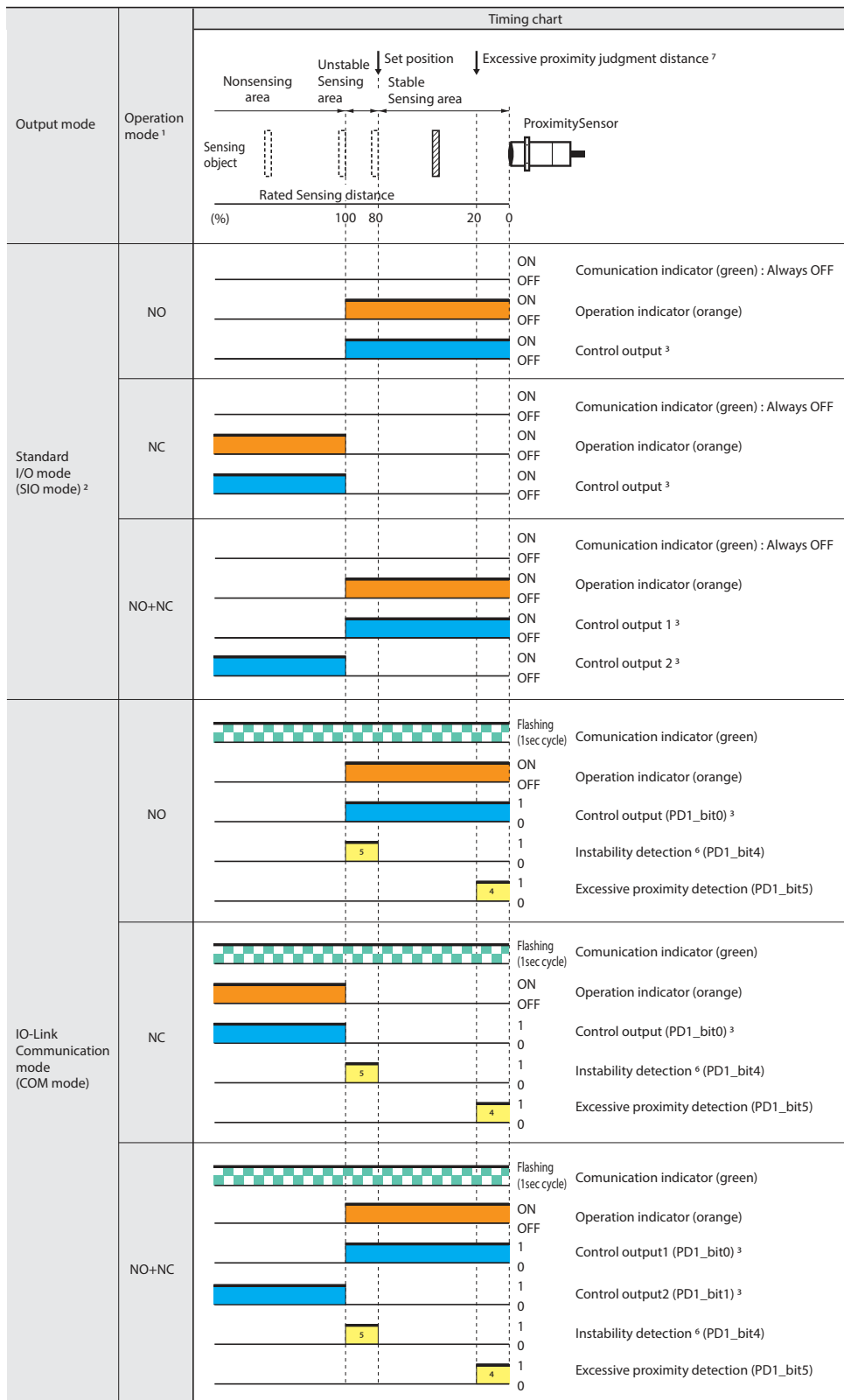

- For models with IO-Link, the operation mode can be changed by the IO-Link communications.
- If using a model with IO-Link as a general sensor or using a model without IO-Link, it operates in the standard I/O mode (SIO mode).
- The timer function of the control output can be set up by the IO-Link communications. (It is able to select ON delay, OFF delay, one-shot, or ONOFF delay function and select a timer time of 1 to 16,383ms (T).)

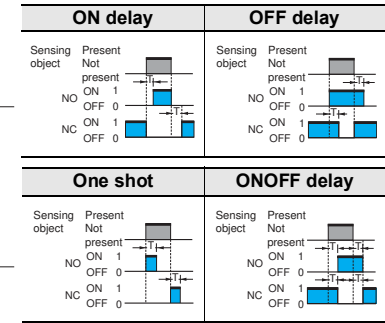

- The excessive proximity diagnosis function can be selected by the IO-Link communications.
- The instability detection diagnosis can be selected by the IO-Link communications.
- The judgment time for the instability detection diagnosis can be selected by the IO-Link communications. (For the ON delay timer function, the setting can be selected from 0 (invalid), 10, 50, 100, 300, 500, or 1000 ms.)
- The judgment distance of the excessive proximity diagnosis function can be selected by the IO-Link communications. (The distance can be selected as a combination of the material of the object detected, such as iron, aluminum, or SUS and the judgment distance of approximately 10, 20, or 30%. However, it is not allowed to select a combination of aluminum and 10%.)

Please contact your Omron sales representative regarding the IO-Link setup file (IODD file).

Please contact your Omron sales representative regarding assignment of data.

DC 3-wire

PNP output

BASIC Model

Operation mode	Model	Timing chart	Output circuit
NO	E2EW-(Q)X□B1	<p>ProximitySensor</p> <p>ON Operation indicator (orange)</p> <p>ON Control output</p>	
NC	E2EW-(Q)X□B2	<p>ProximitySensor</p> <p>ON Operation indicator (orange)</p> <p>ON Control output</p>	
NO+NC	E2EW-(Q)X□B3	<p>ProximitySensor</p> <p>ON Operation indicator (orange)</p> <p>ON Control output 1</p> <p>ON Control output 2</p>	

Connector Pin Arrangement

M12 Smartclick Connector



E2EW Series

DC 3-wire

NPN OUTPUT

PREMIUM Model

Operation mode	Model	Timing chart	Output circuit
NO	E2EW-(Q)X□C1	<p>ProximitySensor</p> <p>ON Operation indicator OFF (orange) ON Control output OFF</p>	<p>DC10 to 30V Brown (1) +V Load OUT Black (4) Blue (3) 0V</p>
NC	E2EW-(Q)X□C2	<p>ProximitySensor</p> <p>ON Operation indicator OFF (orange) ON OFF Control output</p>	<p>DC10 to 30V Brown (1) +V Load OUT Black (2) Blue (3) 0V</p>

Connector Pin Arrangement

M12 Smartclick Connector



DC 3-wire

NPN OUTPUT **BASIC Model**

Operation mode	Model	Timing chart	Output circuit
NO	E2EW-(Q)X□C1		
NC	E2EW-(Q)X□C2		
NO+NC	E2EW-(Q)X□C3		

Connector Pin Arrangement

M12 Smartclick Connector



E2EW Series

Connections for Sensor I/O Connectors

DC 3-Wire

Proximity Sensor				Sensor I/O Connectors	
Types	Output	Operation mode	Model	Model	Connections *1
DC 3-Wire (M12 Smartclick Connector)	PNP	NO	E2EW-(Q)X□B1□-M1TJ	XS5F-D421-□80-X□ XS5F-D42□-□80-F XS5W-D421-□81-X□ XS5W-D42□-□81-F Note: For details of the connector, refer to XS5 Series on page 42.	
		NC	E2EW-(Q)X□B2□-M1TJ		
		NO+NC	E2EW-(Q)X□B3□-M1TJ		
	NPN	NO	E2EW-(Q)X□C1□-M1TJ		
		NC	E2EW-(Q)X□C2□-M1TJ		
		NO+NC	E2EW-(Q)X□C3□-M1TJ		

*1. If the XS5W Series Connector which has a socket and plug on the cable ends is connected to the Sensor, this part will be a plug.

*2. Different from Proximity Sensor wire colors.



Safety Precautions

Be sure to read the precautions for all models in the website at: <http://www.ia.omron.com/>.

Warning Indications

 WARNING	Warning level Indicates a potentially hazardous situation which, if not avoided, will result in minor or moderate injury, or may result in serious injury or death. Additionally there may be significant property damage.
Precautions for Safe Use	Supplementary comments on what to do or avoid doing, to use the product safely.
Precautions for Correct Use	Supplementary comments on what to do or avoid doing, to prevent failure to operate, malfunction or undesirable effect on product performance.

Meaning of Product Safety Symbols

	General prohibition Indicates the instructions of unspecified prohibited action.
	Caution, explosion Indicates the possibility of explosion under specific conditions.

WARNING

This product is not designed or rated for ensuring safety of persons either directly or indirectly. Do not use it for such purposes.



Otherwise, explosion may result. Never use the product with an AC power supply.



Precautions for Safe Use

The following precautions must be observed to ensure safe operation.

- Do not use the product in environments subject to flammable or explosive gases.
- Do not attempt to disassemble, repair, or modify the product.
- Do not use a voltage that exceeds the rated operating voltage range.
Applying a voltage that is higher than the operating voltage range may result in explosion or fire.
- Be sure that the power supply polarity and other wiring is correct. Incorrect wiring may cause explosion or fire.
- If the power supply is connected directly without a load, the internal elements may explode or burn.
- Dispose of the product according to applicable regulations (laws).

Precautions for Correct Use

Do not use the product in any atmosphere or environment that exceeds the ratings.

Operating Environment

- Do not install the Sensor in the following locations.
 - Outdoor locations directly subject to sunlight, rain, snow, water droplets, or oil.
 - Locations subject to atmospheres with chemical vapors, in particular solvents and acids.
 - Locations subject to corrosive gases.
- The Sensor may malfunction if used near ultrasonic cleaning equipment, high-frequency equipment, transceivers, cellular phones, inverters, or other devices that generate a high-frequency electric field. Please refer to the Precautions for Correct Use on the OMRON website (www.ia.omron.com) for typical measures.
- Laying the Proximity Sensor wiring in the same conduit or duct as high-voltage wires or power lines may result in incorrect operation and damage due to induction. Wire the Sensor using a separate conduit or independent conduit.
- Never use thinner or other solvents. Otherwise, the Sensor surface may be dissolved.
- When turning on the power by influence of temperature environment, an output mis-pulse sometimes occurs. After the sensor has passed for 300 msec after turning on, please use in the stable state.
- The sensor is adjusted with a high degree of accuracy, so do not use in the environment with sudden temperature change.
- Operation check is performed using an OMRON's IO-Link master. If using an IO-Link master from another company, perform the operation check in advance.
- When connecting non IO-Link compliant models to the IO-Link master, use the SIO mode.
- In the IO-Link mode, the cord between the IO-Link master and sensor must have a length of 20 m or less.

E2EW Series

Design

Influence of Surrounding Metal

When mounting the Proximity Sensor, ensure that the minimum distances given in the following table are maintained.
If you use a nut, only use the provided nut. And ensure that the minimum distances between the sensing surface and nut is bigger than the "L" given in the following table.
Other non-ferrous metals affect sensor's performance in the same way as aluminum. Perform the operation check in advance.

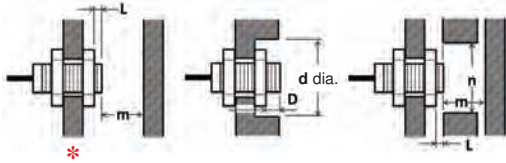

(Unit: mm)

Mounting panel material: Iron

Models	Model	L	d	D	m	n
Quadruple distance model	E2EW-(Q)X12□18	6	54	6	36	54
	E2EW-(Q)X22□30	8	90	8	66	90
Triple distance model	E2EW-(Q)X10□18	2	54	2	30	54
	E2EW-(Q)X20□30	0	30	0	60	90
Single distance model	E2EW-(Q)X2□12	0	12	0	8	40
	E2EW-(Q)X5□18	0	18	0	20	60
	E2EW-(Q)X10□30	0	30	0	40	100

Mounting panel material: Aluminum

Models	Model	L	d	D	m	n
Quadruple distance model	E2EW-(Q)X12□18	12	80	12	36	80
	E2EW-(Q)X22□30	16	120	16	66	120
Triple distance model	E2EW-(Q)X10□18	12	80	12	30	80
	E2EW-(Q)X20□30	16	120	16	60	120
Single distance model	E2EW-(Q)X2□12	12	70	12	8	70
	E2EW-(Q)X5□18	12	80	12	20	80
	E2EW-(Q)X10□30	16	120	16	40	120

* If you use the model E2EW-(Q)X22□30, or E2EW-(Q)X20□30, the panel thickness (t) is 3 mm or less.

When the Proximity Sensor is mounted in metal, ensure that the minimum distances given in the following table are maintained.

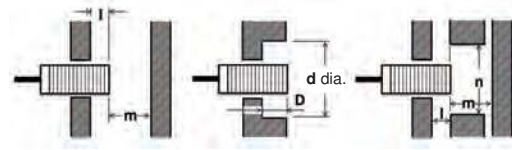

(Unit: mm)

Embedded material: Iron

Models	Model	l	d	D	m	n
Quadruple distance model	E2EW-(Q)X12□18	6	54	6	36	54
	E2EW-(Q)X22□30	8	90	8	66	90
Triple distance model	E2EW-(Q)X10□18	0	18	0	30	54
	E2EW-(Q)X20□30	0	30	0	60	90
Single distance model	E2EW-(Q)X2□12	0	12	0	8	40
	E2EW-(Q)X5□18	0	18	0	20	60
	E2EW-(Q)X10□30	0	30	0	40	100

Embedded material: Aluminum

Models	Model	l	d	D	m	n
Quadruple distance model	E2EW-(Q)X12□18	12	80	12	36	80
	E2EW-(Q)X22□30	16	120	16	66	120
Triple distance model	E2EW-(Q)X10□18	12	80	12	30	80
	E2EW-(Q)X20□30	16	120	16	60	120
Single distance model	E2EW-(Q)X2□12	12	70	12	8	70
	E2EW-(Q)X5□18	12	80	12	20	80
	E2EW-(Q)X10□30	16	120	16	40	120

Mutual Interference

When installing two or more Proximity Sensors face-to-face or side-by-side, ensure that the minimum distances given in the following table are maintained.

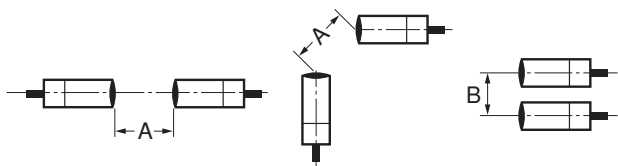

(Unit: mm)

Models	Model	Item	
		A	B
Quadruple distance model	E2EW-(Q)X12□18	80	60
	E2EW-(Q)X22□30	135	110
Triple distance model	E2EW-(Q)X10□18	80	60
	E2EW-(Q)X20□30	135	110
Single distance model	E2EW-(Q)X2□12	40	35
	E2EW-(Q)X5□18	65	60
	E2EW-(Q)X10□30	110	100

Chips from Cutting Aluminum

Normally, chips from cutting aluminum will not cause a detection signal to be output even if it adheres to or accumulates on the detection surface. In the following cases, however, a detection signal may be output.

Remove the cutting chips in these cases.

1. If $d \geq 2/3D$ at the center of the detection surface where d is the cutting chip size and D is the detection surface size

(Unit: mm)

Model	Dimension	D
E2EW-(Q)X□12		10
E2EW-(Q)X□18		16
E2EW-(Q)X□30		28

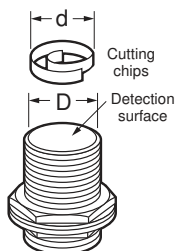

2. If the cutting chips are pressed down

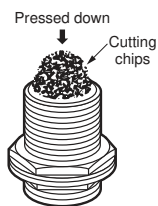

Mounting

Tightening Force

Do not tighten the nut with excessive force.

A washer must be used with the nut.

The tightening force must be the same or less than the figures in the following table.



Quadruple distance model, Triple distance model, Single distance model

Size	Torque	
	E2EW-X□	E2EW-QX□
M12	30 N·m	15 N·m
M18	70 N·m	35 N·m
M30	180 N·m	60 N·m

Note: When mounting the Proximity Sensor, only use the provided nut. Do not use set screws. The Sensor may malfunction.

E2EW Series

Dimensions

(Unit: mm)

Tolerance class IT16 applies to dimensions in this data sheet unless otherwise specified.

Sensors

PREMIUM Model

E2EW/E2EW-Q Series

(Quadruple distance/Triple distance/Spatter-resistant Quadruple distance, Spatter-resistant Triple distance model)

Pre-wired Model



E2EW-X12□□□18/E2EW-QX12□□□18
E2EW-X10□□□18/E2EW-QX10□□□18

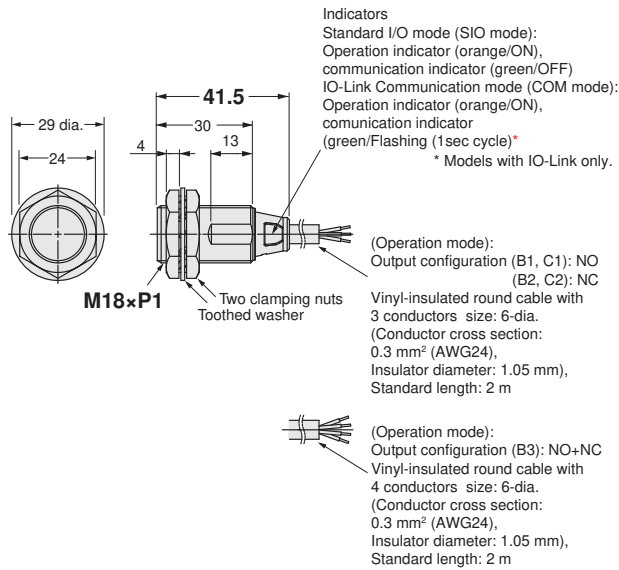

Pre-wired Connector Model



E2EW-X12□□□18-M1TJ
E2EW-X10□□□18-M1TJ
E2EW-QX12□□□18-M1TJ
E2EW-QX10□□□18-M1TJ

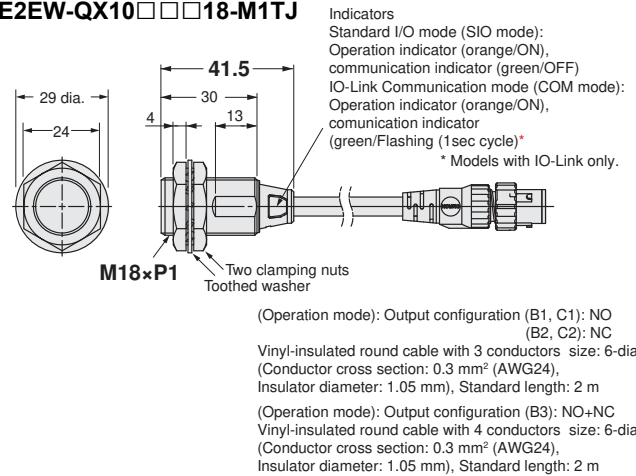

E2EW-X22□□□30/E2EW-QX22□□□30
E2EW-X20□□□30/E2EW-QX20□□□30

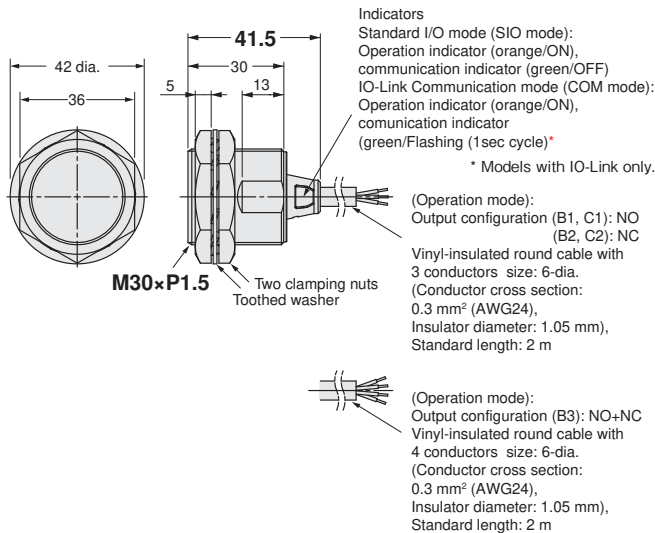

E2EW-X22□□□30-M1TJ
E2EW-X20□□□30-M1TJ
E2EW-QX22□□□30-M1TJ
E2EW-QX20□□□30-M1TJ

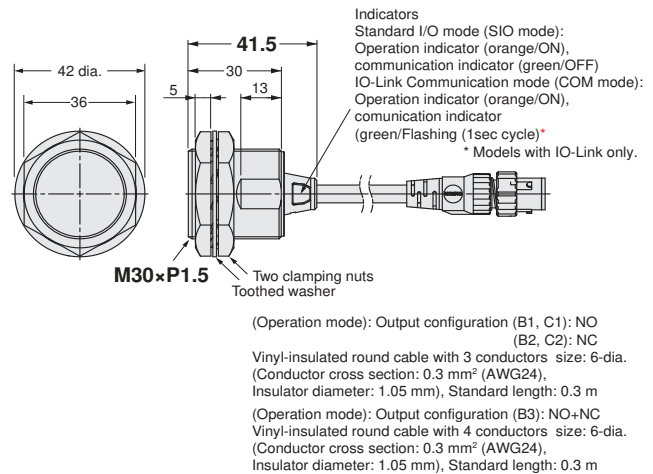

Mounting Hole Dimensions

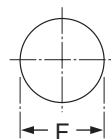

Dimensions	F (mm)
M18	18.5 dia. ^{+0.5} / ₀
M30	30.5 dia. ^{+0.5} / ₀

Angle R of the Bending Wire

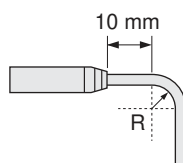

Dimensions	R (mm)
M18	18
M30	18

BASIC Model

E2EW/E2EW-Q Series (Single distance model/Spatter-resistant Single distance model)

Pre-wired Model



E2EW-X2□□12 E2EW-QX2□□12

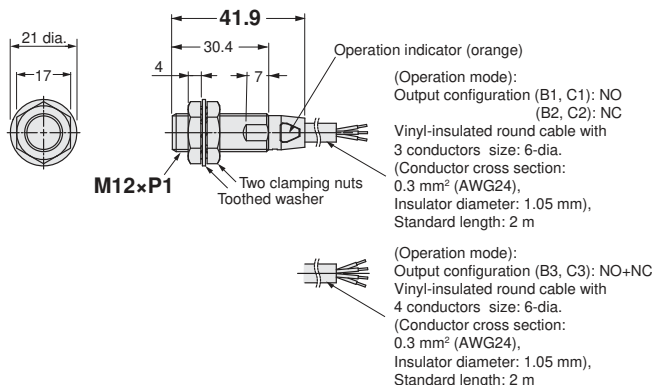

Pre-wired Connector Model



E2EW-X2□□12-M1TJ E2EW-QX2□□12-M1TJ

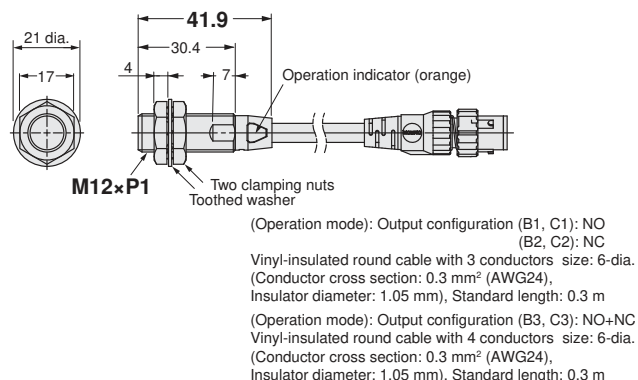

E2EW-X5□□18 E2EW-QX5□□18

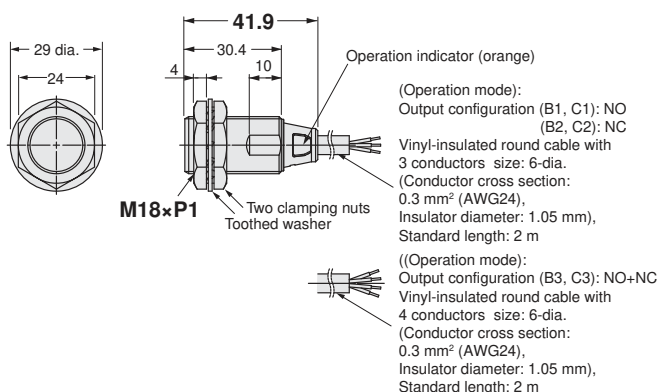

E2EW-X5□□18-M1TJ E2EW-QX5□□18-M1TJ

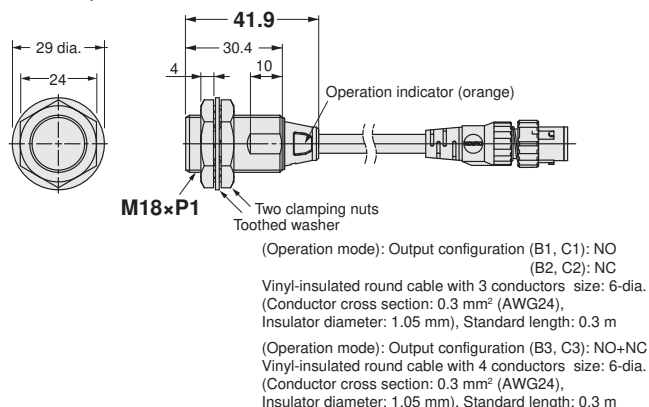

E2EW-X10□□30 E2EW-QX10□□30

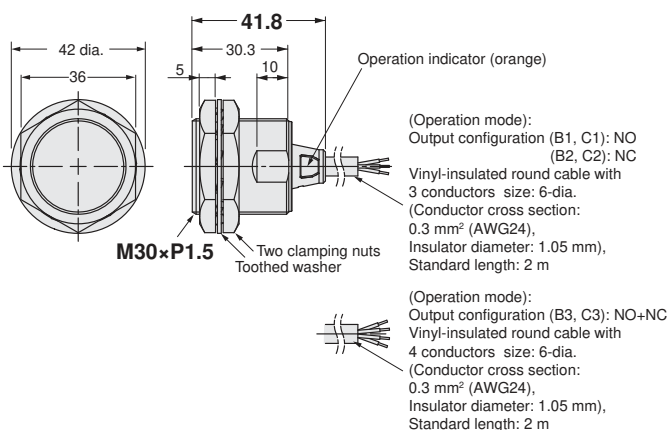

E2EW-X10□□30-M1TJ E2EW-QX10□□30-M1TJ

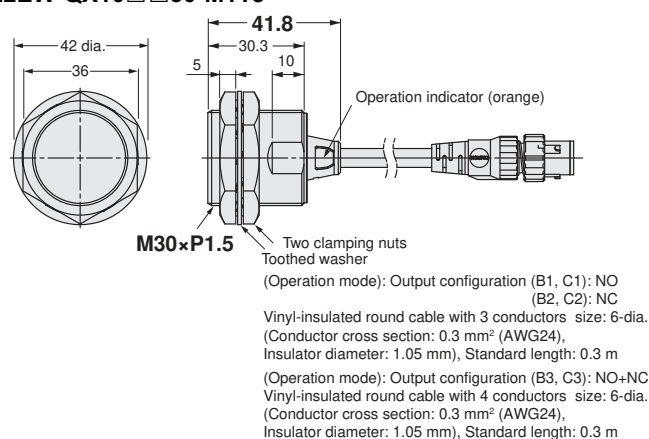

Mounting Hole Dimensions

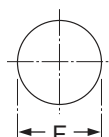

Dimensions	F (mm)
M12	12.5 dia. $\begin{smallmatrix} +0.5 \\ 0 \end{smallmatrix}$
M18	18.5 dia. $\begin{smallmatrix} +0.5 \\ 0 \end{smallmatrix}$
M30	30.5 dia. $\begin{smallmatrix} +0.5 \\ 0 \end{smallmatrix}$

Angle R of the Bending Wire

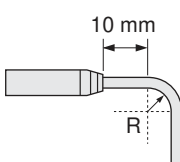

Dimensions	R (mm)
M12	18
M18	
M30	

OMRON AUTOMATION AMERICAS HEADQUARTERS • Chicago, IL USA • 847.843.7900 • 800.556.6766 • automation.omron.com

OMRON CANADA, INC. • HEAD OFFICE

Toronto, ON, Canada • 416.286.6465 • 866.986.6766 • automation.omron.com

OMRON ELECTRONICS DE MEXICO • HEAD OFFICE

Ciudad de México • 52.55.5901.4300 • 01.800.386.6766 • mela@omron.com

OMRON ELECTRONICS DE MEXICO • SALES OFFICE

San Pedro Garza García, N.L. • 81.12.53.7392 • 01.800.386.6766 • mela@omron.com

OMRON ELECTRONICS DE MEXICO • SALES OFFICE

Eugenio Garza Sada, León, Gto • 01.800.386.6766 • mela@omron.com

OMRON ELETRÔNICA DO BRASIL LTDA • HEAD OFFICE

São Paulo, SP, Brasil • 55.11.2101.6300 • www.omron.com.br

OMRON ARGENTINA • SALES OFFICE

Buenos Aires, Argentina • +54.11.4521.8630 • +54.11.4523.8483
mela@omron.com

OTHER OMRON LATIN AMERICA SALES

+54.11.4521.8630 • +54.11.4523.8483 • mela@omron.com

Authorized Distributor:

Controllers & I/O

- Machine Automation Controllers (MAC) • Motion Controllers
- Programmable Logic Controllers (PLC) • Temperature Controllers • Remote I/O

Robotics

- Industrial Robots • Mobile Robots

Operator Interfaces

- Human Machine Interface (HMI)

Motion & Drives

- Machine Automation Controllers (MAC) • Motion Controllers • Servo Systems
- Frequency Inverters

Vision, Measurement & Identification

- Vision Sensors & Systems • Measurement Sensors • Auto Identification Systems

Sensing

- Photoelectric Sensors • Fiber-Optic Sensors • Proximity Sensors
- Rotary Encoders • Ultrasonic Sensors

Safety

- Safety Light Curtains • Safety Laser Scanners • Programmable Safety Systems
- Safety Mats and Edges • Safety Door Switches • Emergency Stop Devices
- Safety Switches & Operator Controls • Safety Monitoring/Force-guided Relays

Control Components

- Power Supplies • Timers • Counters • Programmable Relays
- Digital Panel Meters • Monitoring Products

Switches & Relays

- Limit Switches • Pushbutton Switches • Electromechanical Relays
- Solid State Relays

Software

- Programming & Configuration • Runtime