



UR10e

Technical Specification

Our most versatile robot, the UR10e delivers an impressive payload of 12.5 kg and 1300 mm reach, making it ideal for a wide range of applications.

Today, more than 75,000 UR collaborative industrial robots have been delivered to customers across industries and around the world. UR10e is one of four e-Series cobots, each with a different payload and reach combination. e-Series brings incredible flexibility and unparalleled ease of use to your application.

Updated November 2023.

Copyright © 2023 by Universal Robots A/S. All rights reserved.

UR10e

Specification

Payload	12.5 kg (27.5 lbs)
Reach	1300 mm (51.2 in)
Degrees of freedom	6 rotating joints
Programming	12 inch touchscreen with PolyScope graphical user interface
Power consumption (average)	
Maximum power	615 W
Moderate operating settings	350 W
Operating temperature range	Ambient temperature: 0-50°C (32-122°F)
Safety functions	17 configurable safety functions
In compliance with	EN ISO 13849-1 (PLD Category 3) and EN ISO 10218-1

Performance

Force sensing, tool flange/torque sensor	Force, x-y-z	Torque, x-y-z
Range	100.0 N	10.0 Nm
Precision	5.0 N	0.2 Nm
Accuracy	5.5 N	0.5 Nm

Movement

Typical TCP speed	1 m/s
Pose Repeatability per ISO 9283	± 0.05 mm
Axis movement	Working range Maximum speed
Base	± 360° ± 120°/s
Shoulder	± 360° ± 120°/s
Elbow	± 360° ± 180°/s
Wrist 1	± 360° ± 180°/s
Wrist 2	± 360° ± 180°/s
Wrist 3	± 360° ± 180°/s

Features

IP classification	IP54 water protection
Cleanroom classification	Class 5 at 20 and 40 % at max. speed and payload, Class 6 at 80% at max. speed and payload
ISO 14644-1 classification of air cleanliness by particle concentration	
Noise	< 65 dB(A)
Robot mounting	Any orientation
I/O Ports	
Digital In	2
Digital Out	2
Analog In	2
Tool I/O power supply voltage	12/24 V
Tool I/O power supply	2 A (Dual pin) 1 A (Single pin)

Physical

Footprint	Ø 190 mm
Materials	Aluminum, plastic, steel
Tool Flange	EN ISO-9409-1-50-4-M6
Connector type	M8 M8 8-pin
Cable length (robot arm)	6 m (236 in)
	12 m (472 in) and high-flex options available.
Weight including cable	33.5 kg (73.9 lbs)
Humidity	≤ 90% RH (non-condensing)

Contact

Universal Robots A/S
 Energivej 25
 5260 Odense
 Denmark
 +45 89 93 89 89
sales@universal-robots.com
universal-robots.com

3-Position Enabling Teach Pendant

Features

IP classification	IP54
Included in certifications	EN ISO 10218-1 EN ISO 13849-1
Humidity	≤ 90% RH (non-condensing)
Display resolution	1280 x 800 pixels

Physical

Materials	Plastic
Teach Pendant size (W x H x D)	300 mm x 231 mm x 50 mm (11,8 in x 9,1 in x 1,97 in)
Weight	1,8 kg (3,961 lbs) including 1 m of teach pendant cable
Cable length	4,5 m (177,17 in)

Control Box

Features

IP Classification	IP44
ISO 14644-1 class cleanroom	6
Operating temperature range*	0-50°C (32-122°F)
Humidity	≤ 90% RH (non-condensing)
I/O Ports	
Digital In	16
Digital Out	16
Analog In	2
Analog Out	2
Quadrature Digital Inputs	4
I/O Power Supply	24V, 2A
Communication	500 Hz Control frequency Modbus PROFINET, PROFIsafe (optional) TCP USB 2.0, USB 3.0 Ethernet/IP USB 2.0, USB 3.0 PROFINET ROS/ROS2 driver (optional, open source) Euromap-67 (optional) SPI AN-146 (optional) Injection Moulding Machine Interface (IMMI, optional)
Power Source	100-240 VAC, 47-440 Hz

Physical

Control Box Size (W x H x D)	460 mm x 449 mm x 254 mm (18,2 in x 17,6 in x 10 in)
Weight	12 kg (26,5 lbs)
Materials	Powder coated steel

The control box is also available in an OEM version

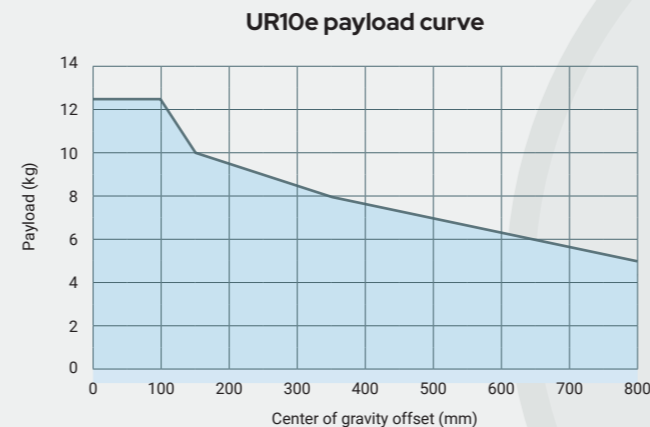

Interface for UR10e base flange

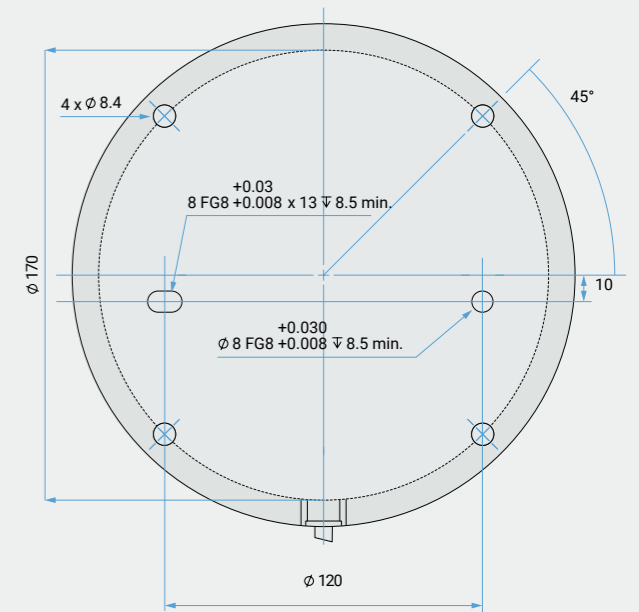

Tool flange for UR3e, UR5e, UR10e and UR16e

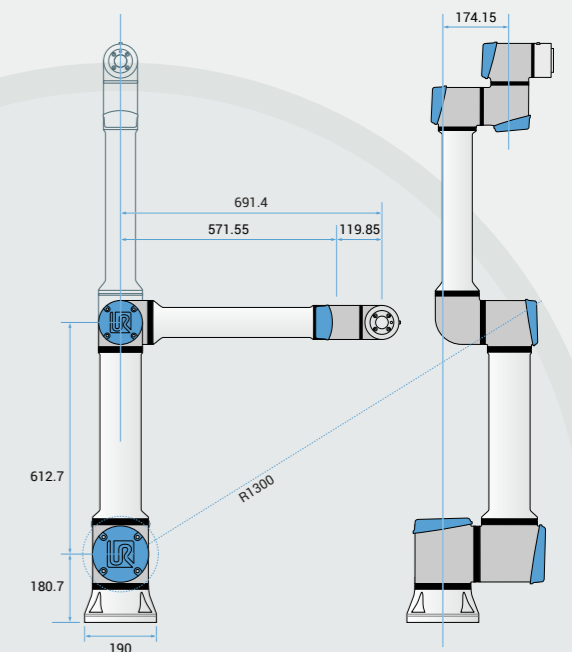
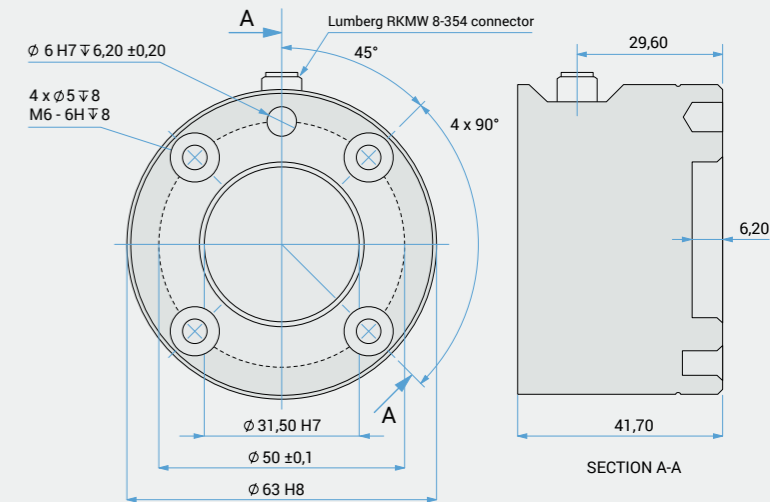

UNLESS OTHERWISE SPECIFIED:
 Dimensions are in millimeters. Tolerance ± 0,1 mm ± 0,5°