

MAX SEAL
Valves & Controls

RESILIENT SEATED BUTTERFLY VALVES

Performance Series

Available in Wafer and Lug Styles

Max-Seal Performance Series valves are designed and manufactured in accordance with the requirements of USCG CFR 46 Category A.

MODELS:

Wafer 51

Lug 52

SIZE RANGE:

2" – 36"

PRESSURE RATING:

2" – 12" 200 WOG / Bidirectional Flow

14" – 24" 175 WOG / Bidirectional Flow

250 WOG – Optional – Unidirectional Flow



DI Nylon
Coated Disc

UNIQUE DESIGN FEATURES:

- Ductile Iron Body
- Rugged Heavy Duty Construction
- High Quality Epoxy Coating for Excellent Corrosion Resistance
- 2-Piece Stem Design Allows for Easy Assembly and Maintenance with Higher Flow Capacity
- ISO Actuator Mounting

AVAILABLE DISC

- 316 Stainless Steel, DI/Nylon coated, Aluminum Bronze
- Special Alloys Available

Max-Seal Concentric Butterfly Valves are backed by the resources and experience of over thirty five years of process valve and automation knowledge.

www.maxsealinc.com

BUTTERFLY VALVE — COMPONENTS / DESIGN FEATURES

Standard parts list

No.	Part	Q'ty	Material	Code
1	Valve Body	1	Ductile Iron A536 Cast Iron Stainless Steel CF8M Bronze ASTM B62	DI CI SS BZ
2	Pin	1	Alloy Steel	
3	O-Ring	1	Buna-N	B
4	Seat Back Up	1	Phenolic	~
5	Seat	1	EPDM Buna-N (Food Grade) Vitron	E B V
6	Lower Shaft	1	Stainless 416 Stainless 316 17-4Ph	S6 SS S7
7	Disc	1	Nylon Coated Ductile Iron Stainless 316 CF8M Stainless 304 CF8 Aluminum Bronze	DI SS S4 AB
8	Upper Shaft	1	Stainless 416 Stainless 316 17-4Ph	S6 SS S7
9	Bushing	1	Fiberglass Reinforced PTFE	T
10	O-Ring	1	Buna-N	B
11	Bushing	1	Fiberglass Reinforced PTFE	T
12	Pin	1	Alloy Steel	
13	Bushing	1	PTFE	T
14	Lower Retainer**	1	Ductile Iron	
15	Upper Retainer**	1	Carbon Steel	
16	Bolts**	4	Carbon Steel	
17	Screw**	4	Carbon Steel	

** For 14"-24" valves

One piece body with extended neck allows clearance for flanges and up to 2½" of insulation.

Primary stem seals are formed by preloaded contact between the disc and seat. A secondary seal is effected by having a stem diameter greater than the stem hole in resilient seat. These seals provide a non-wetted body and stem, eliminating the need for corrosion resistant body material.

Field replaceable, phenolic bonded cartridge is blowout proof, stretch resistant, and non-collapsible, making it an ideal seat design for high velocity or vacuum service. Our resilient seat design eliminates the need for flange gaskets.

Valve sizes 16" & above are supplied with metal seat back up rings.

Max-Seal performance series butterfly valve model number codes

Model	Body Material		Disc Material		Stem Material		Seat Material		Operator		Size inch	Size mm
Wafer-51 Lug-52	Ductile Iron	DI	Nylon Coated Ductile Iron	DI	Stainless 416	S6	EPDM	E	Level	L	2"	50
	Cast Iron	CI	Stainless 316	SS	Stainless 316	SS	BUNA	B	Gear	G	3"	80
	Stainless Steel	SS	Stainless 304	S4	Stainless 410	S0	VITON	V	Bare Stem	N	4"	100
					17-4Ph	S7	TEFLON	T	Actuator	A	6"	150
					Monel	MO					8"	200

Accurate and smooth machined profile of disc edge requires minimal deformation of the resilient elastomer liner to achieve a positive seal. The low deformation results in low torque, less wear of the seat liner, and increased operational life.

Ordering Example by Part Number

Wafer	Ductile Iron	Stainless 316	Stainless 316	BUNA	Level	4"
Model	Body	Disc	Stem	Seat	Operator	Size
51	DI	SS	SS	B	L	100

O-Rings are moulded in seat stem hole as standard

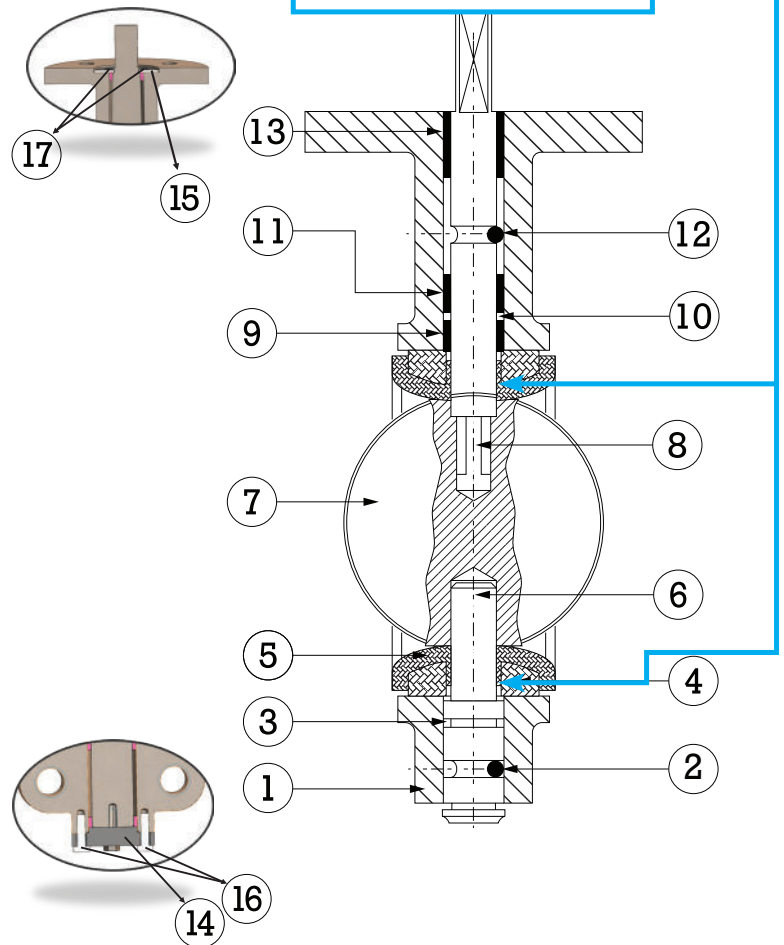

- High strength, square drive (2"-14") ensures a positive shaft to disc connection.
- Square drive offers direct ISO mounting of gear operator and automation equipment.
- Disc floats inside the seat for positive sealing and extended seat life.
- No pins or bolts exposed to flow.
- Offset shaft retainers mechanically retain the shaft in the body ensuring a blow out proof stem design.

Max-Seal Performance Series Valves Are Bidirectionally Bubble Tight. They Are Marked With An Arrow Indicating The Preferred High Pressure Side.

DIMENSIONS / TECHNICAL DATA

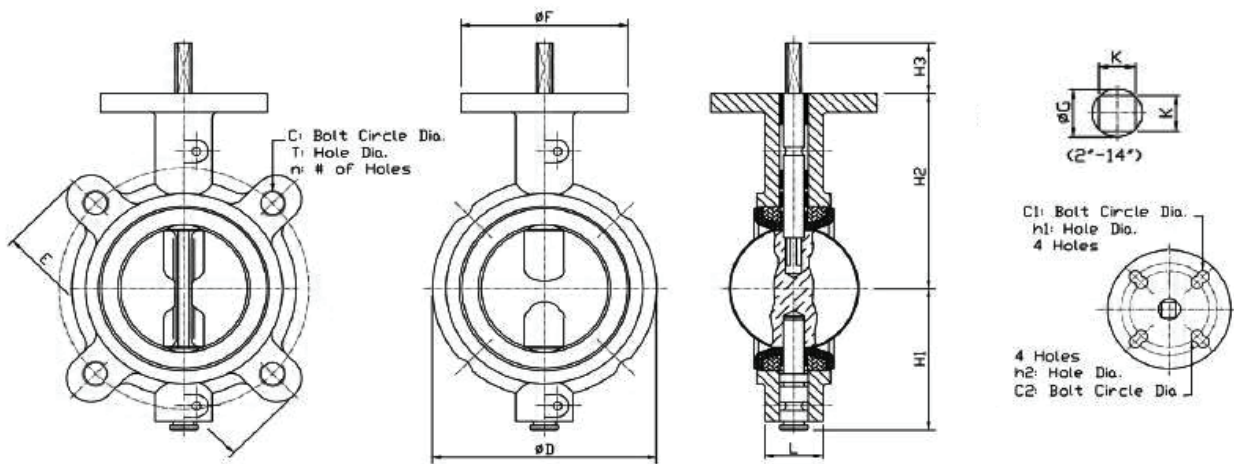

Note:
Verify mounting dimensions before manufacturing mounting hardware

ANSI Class 125 Concentric Butterfly Valves

Size		D	E	L	H1	H2	H3	H4	F	G	K	Flange Dimension			Mounting Base				Weight, lb		
inch	mm											C	T	n	C1	h1	C2	h2	ISO	wafer	lug
2	50	4.125	6.00	1.656	3.11	3.94	1.25	1.14	4.0	0.50	0.354	4.75	5/8-11unc	4	3.25	0.41	2.76	0.39	F07	5	7
2.5	65	4.875	7.00	1.75	3.46	4.59	1.25	1.37	4.0	0.50	0.433	5.50	5/8-11unc	4	3.25	0.41	2.76	0.39	F07	6.5	9
3	80	5.375	7.50	1.78	3.81	5.32	1.25	2.00	4.0	0.50	0.433	6.00	5/8-11unc	4	3.25	0.41	2.76	0.39	F07	7	9
4	100	6.875	9.00	2.05	4.49	6.61	1.25	2.00	4.0	0.625	0.433	7.50	5/8-11unc	8	3.25	0.41	2.76	0.39	F07	10.5	15.5
5	125	7.75	10.0	2.12	5.00	7.17	1.25	2.00	4.0	0.75	0.55	8.50	3/4-10unc	8	3.25	0.41	2.76	0.39	F07	13.5	19.5
6	150	8.75	11.0	2.19	5.51	7.68	1.25	2.00	4.0	0.75	0.55	9.50	3/4-10unc	8	3.25	0.41	2.76	0.39	F07	16.5	23.5
8	200	11.00	13.5	2.38	6.77	9.44	1.75	2.57	6.0	0.875	0.67	11.75	3/4-10unc	8	5.00	0.53	4.01	0.47	F10	31	38.5
10	250	13.38	16.0	2.58	8.03	11.22	1.75	2.88	6.0	1.125	0.87	14.25	7/8-9unc	12	5.00	0.53	4.01	0.47	F10	42.5	59.5
12	300	16.13	19.0	3.03	9.66	12.1	1.75	2.00	6.0	1.25	0.87	17.00	7/8-9unc	12	5.00	0.53	4.01	0.47	F10	65	93.5
14	350	17.16	20.9	3.07	10.7	14.49	1.77	3.6	6.0	1.24	0.87	18.75	1-8unc	12	5.00	0.53	4.01	0.47	F10	99	148
16	400	19.21	23.43	4.02	12.9	15.75	2.83	3.55	7.76	1.49	1.063	21.25	1-8unc	16	n/a	n/a	5.51	0.71	F14	147	215.5
18	450	21.22	25.16	4.49	13.5	16.61	2.83	3.55	7.76	1.69	1.063	22.75	1 1/8-7unc	16	n/a	n/a	5.51	0.71	F14	189	260
20	500	23.35	27.83	5.00	15.1	18.9	2.83	4.3	7.76	1.80	1.417	25.00	1 1/8-7unc	18	n/a	n/a	5.51	0.71	F14	276	384.5
24	600	32.44	32.76	6.06	18.79	22.12	3.23	5.4	10.87	2.13	1.417	29.50	1 1/4-7unc	18	n/a	n/a	6.50	0.87	F16	474	576.5

Larger sizes available through 120", consult factory

- **Pressure Ratings:**
2"-12" 200 psi; 14"-24" 175 psi
- **Lug Body for Dead End Service:**
2"-12" 150 psi; 14"-24" 125 psi
- **Higher Pressure Option:**
250 WOG, Sizes 2"-18"; 220 WOG, Size 20"-24" with 17-4Ph stem & seat modification in lug body
Step Machined in Body Helps Retain Seat Under High Pressure
Max-Seal valves are designed for bubble tight shutoff in either direction of flow. Each valve is factory tested to 110% of their pressure rating

Blowout-proof stem design

A heavy duty butterfly valve, designed for ANSI Class 125/150 flanges. These comply with MSS-SP25, MSS-SP67, & the requirements of MIL-V-22133C (ship) Type 1, Class A-D

Valve sizes up to 16" meet API 609 standard; Sizes 18"-24" with fine thread drilling meet API 609 standard

• **Positive Valve Position:**

When the handle is parallel to the pipe, the valve is fully open. The orientation of the disc is indicated by a groove at the shaft end that is in line with the disc.

See Tech Bulletin 608-19 for bolting information

Vacuum Service up to 28" Hg

HANDLE AND GEAR OPERATOR DIMENSIONS

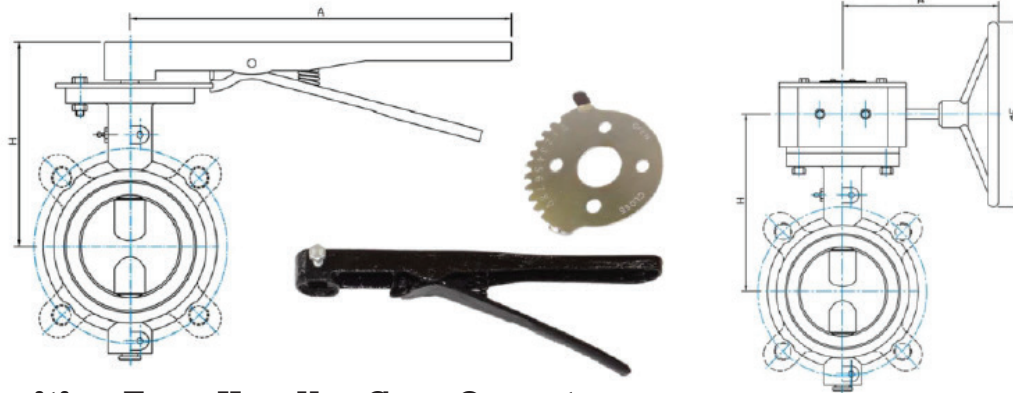

Level-Lock 10 Position Type Handle

Size	2"	2.5"	3"	4"	5"	6"	8"	10"	12"
H	5.19	5.84	6.16	7.25	7.38	7.94	11.19	12.97	13.56
A	10.5	10.5	10.5	10.5	10.5	10.5	14	14	20

Gear Operator

Size	2"	2.5"	3"	4"	5"	6"	8"	10"	12"	14"	16"	18"	20"	24"
H	5.41	6.07	6.38	7.48	7.60	8.16	11.13	12.91	13.45	16.13	18.27	21.42	21.42	24.92
F	5.9	5.9	5.9	5.9	5.9	5.9	11.8	11.8	11.8	11.8	11.8	11.8	11.8	15.35
A	6	6	6	6	6	6	9.84	9.84	9.84	10.94	10.94	10.94	10.49	12.05

VALVE FLOW COEFFICIENTS & TECHNICAL DATA

Max-Seal Valves are ideally suited for actuated applications

Seat Temperature Range

Material	Temperature Range
Buna-N (NBR)	0° to 200° F
EPDM	-40° to 275° F
VITON	0° to 300° F
Neoprene	-60° to 200° F
Hypalon	-40° to 250° F

Different seat and seat backing available consult factory



ACTUATOR MOUNTING

Max-Seal Offers a broad line of automation systems for precise proportioning of on-off control in either pneumatic or electronically powered units.

Cast Mounting Flange Accommodates all types of operators, offering two sets of slotted bolted circles ISO 5211 and industry popular type. It is designed to accept direct actuator mounting, some sizes may require a spacer plate.

Max-Seal Models 51, 51 Cv Value

Size		Angle of Opening								
INCH	MM	10°	20°	30°	40°	50°	60°	70°	80°	90°
2	50	0.1	5	12	24	45	64	90	125	135
2½	65	0.2	8	20	37	65	98	144	204	220
3	80	0.3	12	22	39	70	116	183	275	302
4	100	0.5	17	36	78	139	230	364	546	600
5	125	0.8	29	61	133	237	392	620	930	1022
6	150	2	45	95	205	366	605	958	1437	1579
8	200	3	89	188	408	727	1202	1903	2854	3136
10	250	4	151	320	694	1237	2047	3240	4859	5340
12	300	5	234	495	1072	1911	3162	5005	7505	8250

Streamlined Disc Design Reduces Pressure Drop and Maximizes Cv

Performance Series Torque Value

Size		Pressure Differential		
INCH	MM	50 psi	100 psi	200 psi
2	50	127	147	170
2½	65	135	168	193
3	80	206	225	259
4	100	350	387	445
5	125	525	605	646
6	150	825	997	1147
8	200	1495	1864	2144
10	250	2420	3140	3611
12	300	3612	4767	5482

All torques shown in the above chart can be used for both seating and unseating. Figured for wet service defined as lubricated clean and non abrasive line media.



Max-Seal, Inc.
4815 West 5th St.
Lumberton, NC 28358

P.O. Box 1293
Lumberton, NC 28359
www.maxsealinc.com

910-738-2866
910-739-1733
sales@maxsealinc.com